

# X PUMPS



The X range pumps are designed for the most severe working conditions in terms of :

- **space available ;**
- **drive speed of the pump ;**
- **power required.**

To meet such performance criteria, Hydro Leduc opted for the “bent axis” concept, and optimized the pump design in several ways :

- 7 pistons ;
- original idea for plate – barrel synchronisation ;
- change of direction of rotation by simply changing a fitting ;
- use of materials with high mechanical resistance ;
- reinforced sealing.

The X pumps therefore offer exceptional performance :

- greatly reduced noise levels ;
- high rotating speeds ;
- simple to use ;
- long service life.

The exceptional compacity of the X pumps, together with their technology, means they can be installed in the most challenging size envelopes and where rotating speed – due to the PTO ratio for example – is high.

The X110 pump is the champion in terms of displacement relative to pump size ! 110-litres/minute at 1,000-rpm in a width of less than 110-mm !

## Please note :

For all installations where flow can return back to the pump, a check valve must be included on pump output line to protect the pump.

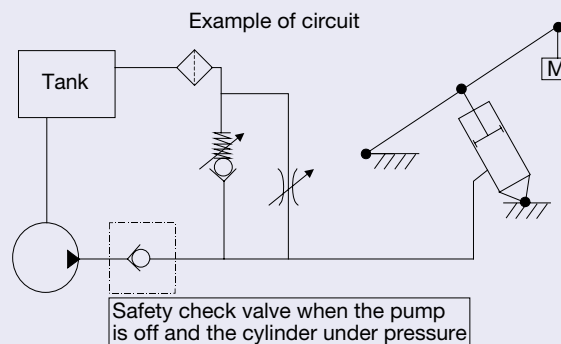

- 8 models : - from 18 to 110 cc*  
*- 350 bar continuous working pressure*  
*- 400 bar peak pressure*  
*- max speed from 1,750 to 2,850 rpm*



**Minimum size envelope**  
**High rotating speeds**  
**High output pressure**

Pump model	Displacement (cc)	Max. pressure		Speed absolute pressure 1 bar (rpm)	Maximum torque absorbed at 350 bar (Nm)	Weight (kgs)
		continuous (bar)	peak ≤ 5 seconds (bar)			
X18 0514450	18	350	400	2850	107	10,2
X25 0514440	25	350	400	2350	148	10,2
X35 0513270	32	350	400	2600	190	10,2
X40 0514430	41	350	400	2200	243	10,2
X50 0513010	50,3	350	400	2200	292	11,8
X65 0512980	63	350	400	2100	362	11,8
X80 0513220	80,4	350	400	2000	460	15,7
X110 0513640	108,3	350	400	1750	619	16

**By-pass valve for X pumps**

For X pump applications where the pump is driven by a continuous running PTO (PTO which cannot be disengaged), Hydro Leduc offers a by-pass valve which is fitted onto the back of the pump. This solution allows the continuous running of the pump :

- without creating problems of fluid overheating ;
- without affecting pump service life ;
- with no modifications necessary to the hydraulic equipment on the truck.

**How does it work ?**

The by-pass valve is a 24 Volt solenoid valve. When not activated, it enables pump output to link up to pump inlet. When it is activated, the pump operates normally (output flow).

Leduc part number:  
**BP65** 0515130 (vor X50 and X65)  
**BP80** 0515120 (vor X80 and X110)



Environment, see page 14

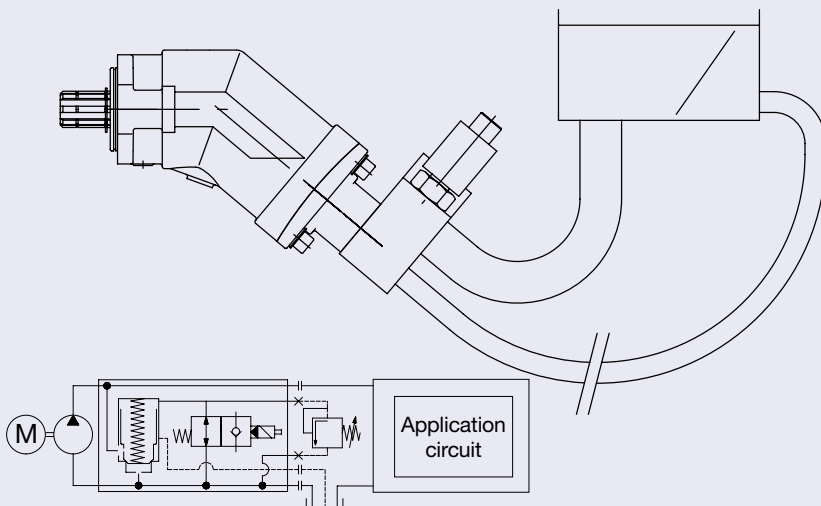

# X PUMPS

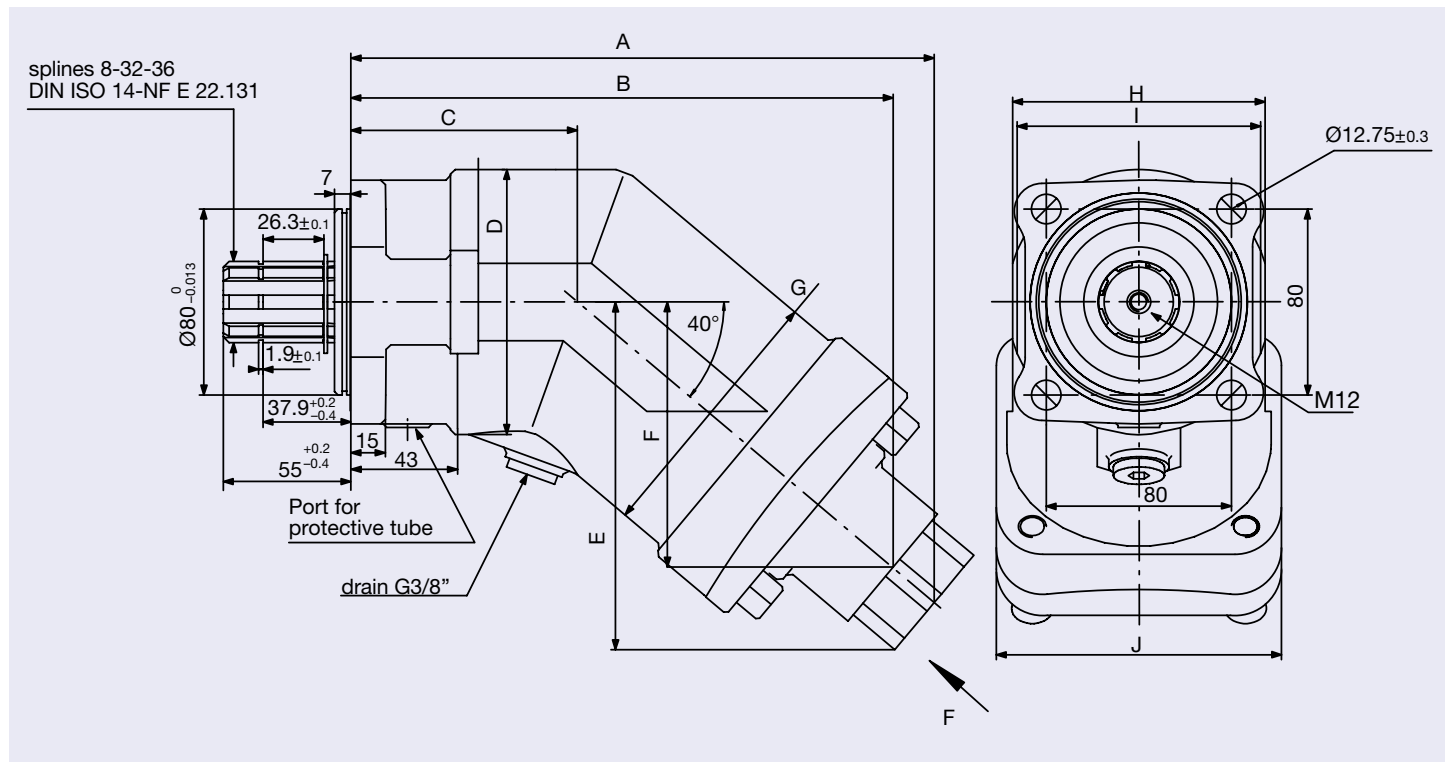

## Dimensions

Dimensions (mm)													
Pump model	A	B	C	ØD	E	F	ØG	H	I	J	K	L	M
X18 0514450	197,5	183,6	86	103	107	82	103	98	98	108	35,76	G3/4"	G1/2"
X25 0514440	197,5	183,6	86	103	107	82	103	98	98	108	35,76	G3/4"	G1/2"
X35 0513270	203,5	189,7	86	103	112,1	87,2	103	98	98	108	39,75	G3/4"	G1/2"
X40 0514430	203,5	189,7	86	103	112,1	87,2	103	98	98	108	39,75	G3/4"	G1/2"
X50 0513010	219,6	203,5	86	103	129,3	98,8	103	98	98	108	49,7	G1"	G3/4"
X65 0512980	219,6	203,5	86	103	129,3	98,8	103	98	98	108	49,7	G1"	G3/4"
X80 0513220	251,7	233,7	97,7	114	149,7	114,3	114	109	105	123	56,3	G1"1/4	G1"
X110 0513640	251,7	233,7	97,7	114	149,7	114,3	114	109	105	123	56,3	G1"1/4	G1"

## How to change the direction of rotation of the pump

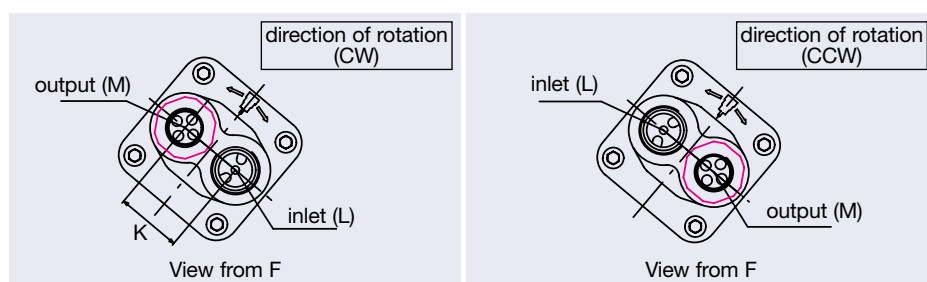

HYDRO LEDUC supplies all X pumps ready for clockwise rotation (CW).

To know in which direction the pump needs to turn on your installation :

- look at the PTO at drive end ;
- if the PTO turns clockwise, the pump should turn anti-clockwise, and vice versa.

To change the direction of rotation of the pump, remove the inlet fitting if there is one, and put it in place of the output fitting. The output fitting should then go in place of previous inlet.

**IMPORTANT :** Do not rotate pump shaft when the pressure (output) fitting is not on the pump.

The pressure fitting should be tightened according to the tightening torque values given in the table on the left.

	X18	X25	X35	X40	X50	X65	X80	X110
Tightening torque (Nm)	70	70	70	70	100	100	180	180
Outlet fittings dimensions / flats (mm)	30/32	30/32	30/32	30/32	41	41	42	42
Inlet fittings dimensions / flats (mm)	32	32	36	36	50	50	54	54

# Performance



## Torque absorbed as a function of pump output pressure

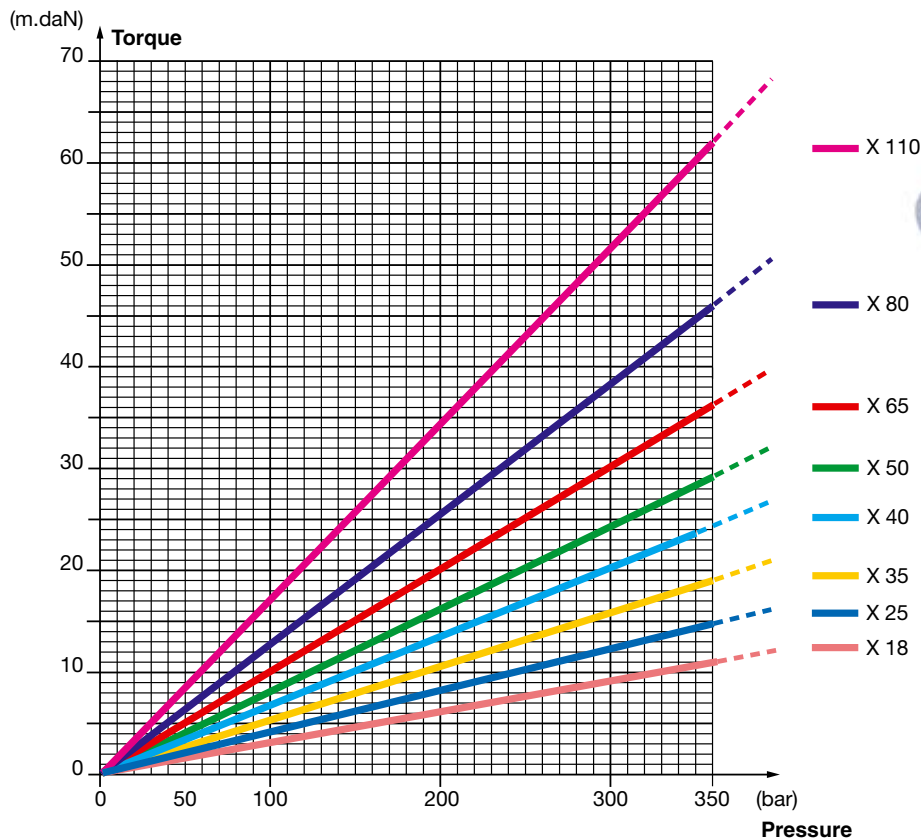

## Flow

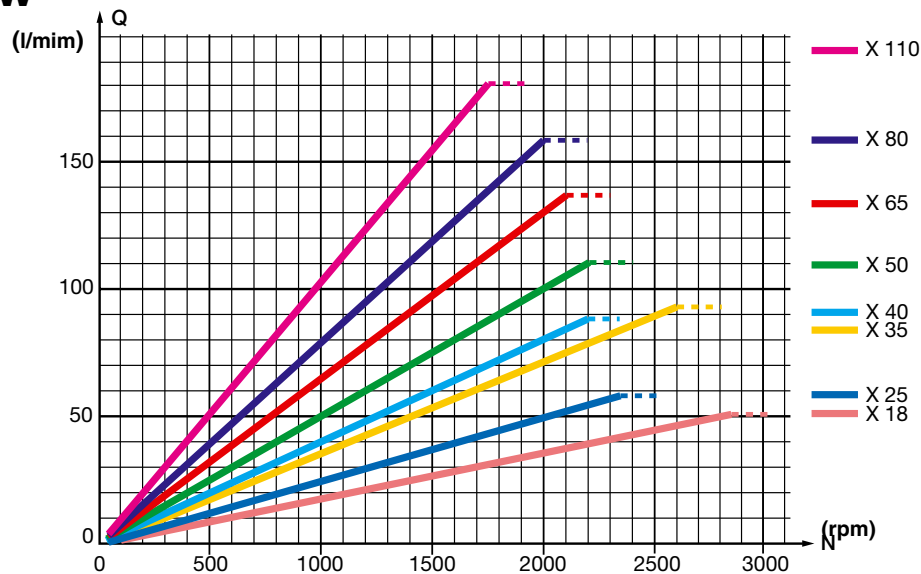

## Volumetric efficiency

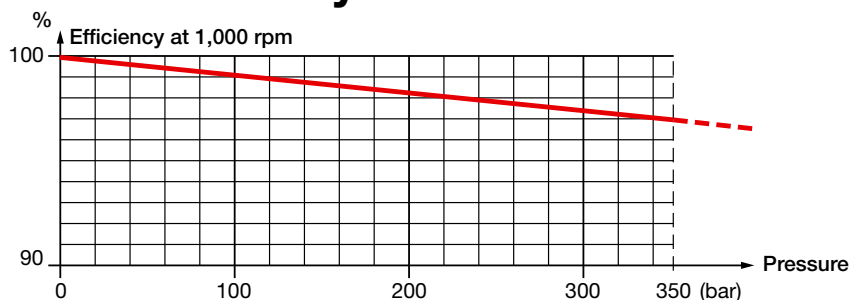

These graphs are the results of testwork done in the HL R&D laboratory, on a specific test bench, with an ISO 46 fluid at 25°C (100 cSt), the pump is fitted with an HL inlet fitting, hosing is 4 metres long, and tank situated slightly above pump.



Environment, see page 14

